

NORTH STAR
HIGH VOLTAGE

12604 N New Reflection Dr
Marana AZ 85653
(520)780-9030; (206)219-4205 FAX
<http://www.highvoltageprobes.com>
probes@highvoltageprobes.com

Voltage Probe Manual and Data
North Star High Voltage, Inc.
March 2008



Safety

High Voltage Safety is important. Always ground the probe to a reliable ground point near the measurement point. Do not touch the probe during high voltage operation. Stay away from malfunctioning high voltage equipment and ground it carefully if it must be touched. Failure to ground the probe near the device under test can also destroy the probe.

General

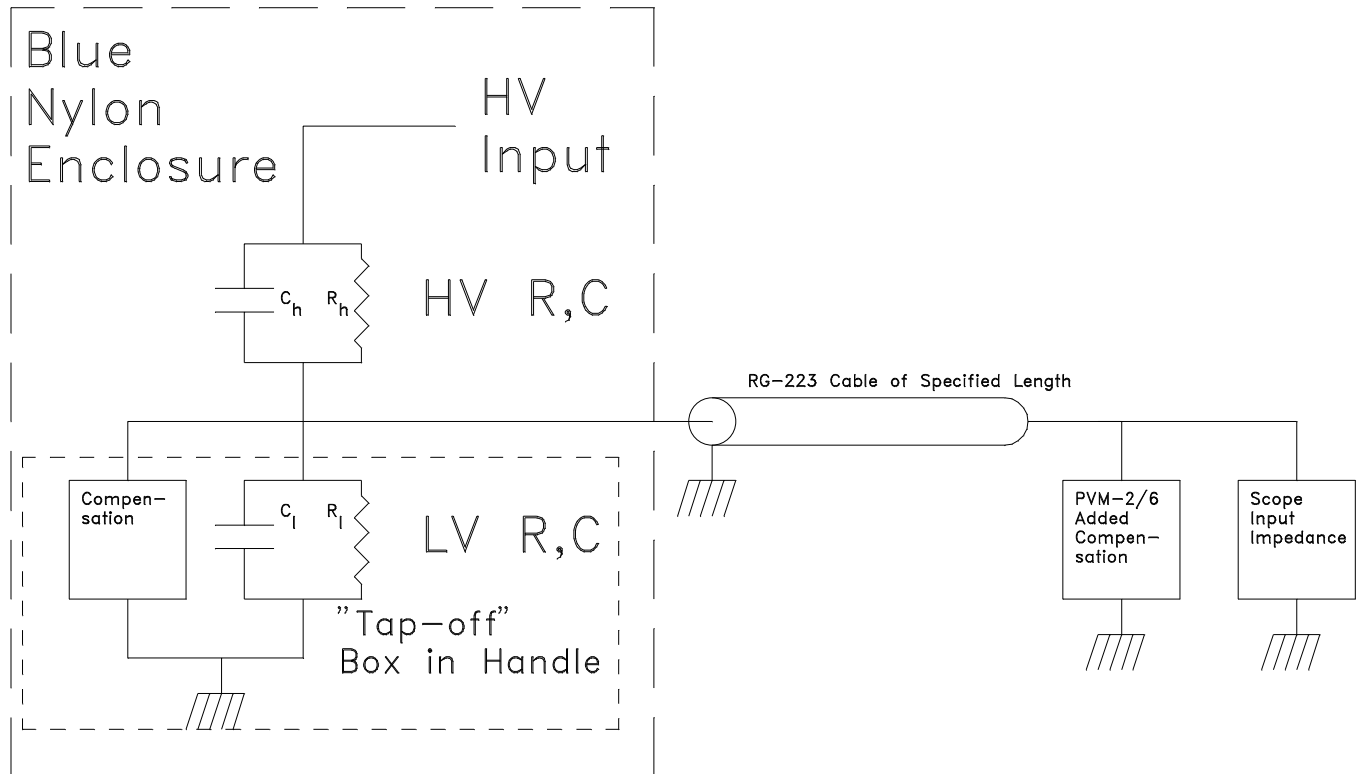

The PVM and VD series high voltage probes are RC dividers designed to produce precisely attenuated signals over a very wide bandwidth. The circuit diagram is shown below. The divider network consists of a high voltage network represented by a parallel capacitor and resistor, and a low voltage network which consists of a parallel RC network and a compensation circuit. The high voltage section of the voltage divider is in the blue nylon oil filled housing. The low voltage section is in the small rectangular box inside the bottom of the handle (PVM series probes) or in the small rectangular box underneath the probe base (VD series probes). The purpose served by placing the low voltage section in a secondary enclosure is that it allows the probe to be provided with multiple "tap-off" boxes, each of which are calibrated for different attenuation factors.

Additional compensation for high frequencies is used in the PVM-2 and PVM-6. Those probes may, subject to custom features, require placement of the additional blue compensation box at the oscilloscope.

The probe is designed to produce the calibrated level of output with a 1 Megohm impedance on the measurement device, and with the specified cable length in place. Changes in cable length tend to change the calibration approximately 0.7 %/ft. for a typical 1000:1 probe. PVM-5 probes tend to have greater variations, while some PVM-1s have smaller variations. The 10,000:1 probes, including the VD series probes, have much smaller variations in calibration with cable length.

The high voltage section of each probe is insulated with Shell Diala-AX transformer oil which does not contain PCBs. The oil does not have any known toxic effects.

Input Impedance for Standard Operation

Standard probes are designed to operate into a 1 megohm oscilloscope. Operation into higher impedance devices such as multi-meters requires a parallel resistance for accurate measurement. For example, a 1.11 Megohm resistance can be placed in parallel with a Hewlett Packard meter (10 Megohm input) to produce a 1 Megohm input impedance. Operation into lower impedance equipment requires factory changes. Read the manual of your measuring instrument to determine its input impedance since many meter manufacturers use different input impedances on different meter scales. Erroneous readings will result with all probes (not just our probes) in that case. For example, a Hewlett Packard high voltage probe will not give correct readings with some Hewlett Packard meters on higher voltage (>30 V) scales.

Proximity Effect and Exclusion Zone

The "proximity effect" (change in calibration when the probe is near ground or near a high voltage node) has been eliminated in all NS probes. Good practice and high voltage safety still dictate that the probe should be spaced away from other conductors by a distance of at least 3 mm/kV (15 cm if the DC voltage is 50 kV). This is particularly true of DC voltage. A high frequency ($f > 50$ Hz) calibration shift of about 0.5 - 1 % is possible if conductors are closer.

High Frequency Measurements

It may be necessary to improve the grounding of the probe in order to clean up noise in very high voltage, high frequency (>20 Mhz) measurements. Specifically, a wide area ground from the bottom of the probe, or additional individual grounds may be required. It may also be necessary to further shield the probe cables at the highest frequencies. The cause of this noise is the ground loop which results if the probe cable carries some of the ground current. Inductive isolators on the probe ground can also be helpful in "choking" ground currents. Note that the impedance presented to the load at 50 Mhz

with a probe with 8 pf. Input capacitance is only 400 ohms, so currents matter.

Connections

In general, the ground clip lead should be connected to the ground of the equipment under test, and the tip of the probe should be connected to the voltage source for PVM series probes. For VD series probes, the signal is connected to the top of the probe, and the ground is connected to the base. At high frequency, the inductance of the ground path must also be minimized. One method of improving high speed measurement is to use multiple grounds in addition to the fly lead provided. Connections should be made with the equipment to be measured turned off. The cylindrical ground lead can also be used for ground connections. The BNC output cable should be connected directly to the oscilloscope. An RG-223 cable (double shielded cable) is provided with all probes. The double shielded cable is essential at high frequencies and it is advantageous at low frequencies. Any 50 ohm (or 93 ohm if appropriate) cable can be used to connect to the measurement instrument as long as that cable has the right capacitance.

Changing the Cable

We recommend that if a different cable than originally supplied is to be used, it should be made from RG-223 cable (except for 93 ohm cable probes) and kept to the same length as the original cable. Connectors can be placed in this cable (for example for penetrating screen room walls). Double shielded cables reduce spurious noise, leading to better performance. RG-223 has a capacitance of 28.5 pf/ft. A 10 ft. increase in cable length will typically change the high frequency calibration by 5 % (the range is 3 - 10 % depending on probe).

Troubleshooting

The repair of most problems with the probe will lead to a requirement for re-calibration. If there is a problem, disassembly of the probe high voltage section is not recommended. Except in unusual situations, North Star will repair the probe without question if it is under warranty. It is much easier for us to ascertain the problem if the probe has not been modified by the user when it is returned to us.

If the probe has no signal output, but is not shorted to ground, the problem may be a poor connection in the tap-off box. The tap-off box can be inspected, and if wires are loose they should be reconnected. Do not adjust the potentiometers in the tap-off box, or re-calibration will be required.

Warranty

The probe is warranted against defects in parts and workmanship for one (1) year after the ship date from North Star. We will repair the probe if an electrical failure occurs

during the first six (6) months after shipping irrespective of the cause of the fault. Shipping from the customer site to North Star will be paid by the customer, and shipping from North Star to the customer will be paid by North Star. North Star will judge whether expedited means of shipping are required.

Mechanical damage due to dropping the probe and extreme thermal damage (melting the probe) may not be covered and should be discussed with North Star before returning the probe. Shipping damage should be reported to North Star immediately.

Please do not open the probe high voltage section if warranty repairs are going to be requested. This increases the work required to repair the probe, and is not effective.

Options:

- 1) Additional tap-off boxes to allow convenient change to other Divider ratios.
- 2) NIST (National Institute of Standards and Technology) traceable calibration DC - 50 kHz, with data supplied to customer.
- 3) The probes may be ordered with 2000:1 instead of 1000:1 attenuation at no added cost. Add -2000 at the end of any part number - for example PVM-6-2000 is the 2000:1 version of the PVM-6
- 4) Included Options - PVM 1 - 6 - A resistance in series with the probe to damp frequencies $> 1.2 \times$ max frequency will be included after July, 2002. This resistor can be removed as required for high repetition rates/ high frequencies.

Standard Probe Data

Model Number	PVM-1	PVM-2	PVM-3	PVM-4	PVM-5	PVM-6	PVM-11 (PVM-10)	PVM-12
Max DC/Pulsed V (kV)	40/60	40/60	40/60	40/60	60/100	60/100	10/12	25/30
Max Frequency (Mhz.)	80	80	40	110	80	80	50	80
Cable Impedance (ohms)	50	50	50	93	50	50	50	50
DC - 2 Hz. accuracy	<0.1%	<0.1 %	<0.1 %	<0.1 %	<0.1%	<0.1%	<0.1 %	<0.1 %
2 Hz. - 200 Hz. accuracy	<1 %	<1. %	<2. %	<1. %	<1%	<1%	<1.5 %	<1.5 %
200 Hz. - 5 Mhz. accuracy	<1.5%	<1.5%	<3%	<1.5%	<1.5 %	<1.5 %	<2.%	<2.%
> 5 Mhz. Accuracy	<3%	<3%	<4%	<5%	<3%	<4%	<4%	<4%
Input R/C (Megohm/pf)	400/13	400/13	400/10	400/10	400/12	400/12	50/15	150/7
Cable Length (ft./m)	15/4.5	30/9	100/30	15/4.5	15/4.5	30/9	15/4.5	15/4.5
Standard Divider Ratio	1000:1	1000:1	10,000:1	1000:1	1,000:1	1,000:1	1,000:1 (100:1)	1,000:1
Length (inches/cm.)	19/47	19/47	19/47	19/47	19/47	19/47	7/18	9/23

Add -2 to any PVM-1 - PVM-6 or PVM-12 part number for 2000:1 ratio

Model Number	VD-60	VD-100	VD-150	VD-200	VD-300	VD-400
Max DC/Pulsed V (kV)	60/120	100/180	150/240	200/300	300/420	400/550
Max Frequency (Mhz.)	20	20	20	16	12	8
Cable Length (ft.)	30	30	30	30	30	30
DC accuracy	<0.1 %	<0.1 %	<0.1%	<0.1%	<0.1 %	<0.1%
10 Hz. - 1 Mhz. Accuracy	1 %	1 %	1 %	2%	2.5 %	4 %
>1 Mhz Accuracy	3 %	3 %	3 %	3%	4 %	4%
Resistance (Megohms)	800	1600	2000	2800	4500	7000
Height (inches/cm.)	20/50	24/60	30/75	40/99	54/135	72/180
Diameter (in/cm.)	11/28	11/28	12/29	16/40	24/61	24/61
Capacitance (approx. pf)	27	25	27	24	20	16
Base Diameter(in/cm.)	10/25	10/25	12/30	20/50	30/76*	30/76*
Standard Divider Ratio	10,000:1	10,000:1	10,000:1	10,000:1	10,000:1	10,000:1

*Square Base

Probe Voltage in Various Frequency Ranges and Probe Derating

All high voltage probes must be derated due to high frequency (i.e., high RMS) currents, and due to corona and other effects. The following information is suggested as a guideline, although many high voltage systems have their own unique requirements which fall outside these guidelines. For example, square waves can have higher RMS currents than sine waves. For high frequencies in the PVM-1 - PVM-6 remove the black series resistor and replace with a straight connection.

Application to AC up to 400 kHz. AC RMS operating voltage = DC voltage/1.41

Applicability of Pulse Voltage Rating:

Full pulse rating at 10 Hz/20 usec pulse duration 1.5
X DC for VD series to 300 Hz/10 usec pulse duration
1.25 X DC for VD series to 4 kHz/10 usec pulse duration
1.25 X DC for PVM series to 300 Hz/10 usec pulse duration
Derate below DC voltage for CW frequencies above 200 kHz per chart below.

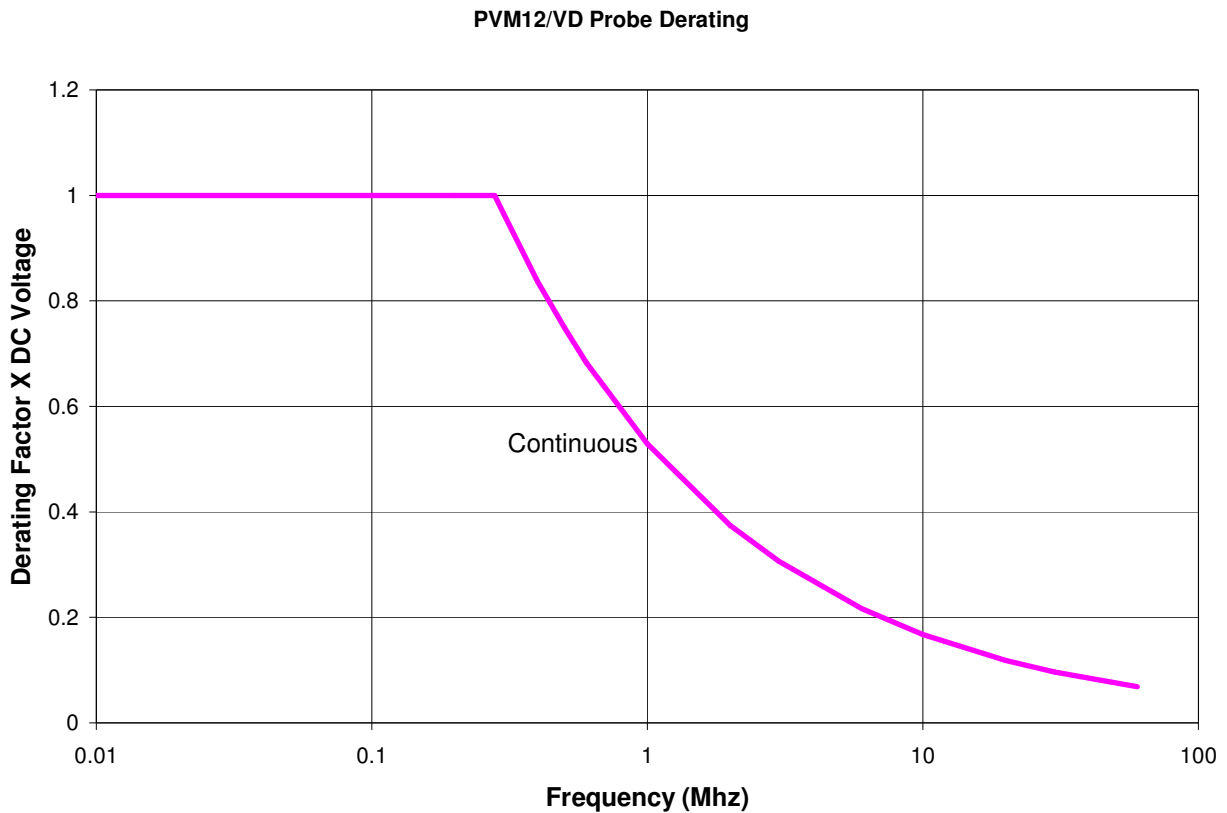

Application Note - High Frequency Connections and Grounding in Voltage Probes

Richard Adler,
North Star Research Corporation, 1996

Measurements made at high frequency are often problematic when the rise-time of signals is fast. The first and foremost requirement for successfully making these measurements is to make sure that the ground used is a well established ground point, and to make sure that the ground signal lead is securely connected.

Undesirable "ringing" can occur when signals which have high frequency components are measured. For example, a square wave with a 3 ns rise-time has a significant amount of energy in frequency components above the 90 Mhz bandwidth of the probe. North Stars PVM series probes tend to have a resonances between 120 Mhz and 200 Mhz due to the length of the probes, and due to capacitive effects. These frequency components may be undesirable - it may be desirable to artificially limit the bandwidth of the probe to 90 Mhz artificially. The method of limiting the bandwidth is quite simple. If we set the RC time product of the high voltage capacitance and an external resistance to equal about 2- 3 nanoseconds, this limits the probe's bandwidth to 90 Mhz. For example, a series resistance of 300 - 400 ohms will limit the rise-time of a PVM-5 or PVM-6 probe. A value of about 250 ohms can be used to limit the bandwidth of a PVM-1,2,3, or 4 probe.

When the probe capacitance C_i is charged, an energy of $0.5C_iV^2$ is dissipated in the series resistor described above. The power dissipation is therefore $0.5fC_iV^2$. For a typical PVM-6 example, the probe's capacitance is 8 pf. or less. At a voltage of 60 kV, and $f = 1000$ Hz, the dissipation in the series resistance is 14 Watts. This resistance must therefore be added with care. In many applications (for example in the detection of 13.56 MHz signals) the use of these resistors is impractical.

Additional Resources

If you need a pulsed power formula try our pulsed power formulary. Download our well-known Pulsed Power Formulary at our web site: <http://www.highvoltageprobes.com/downloads.html>

Very high voltage pulsed measurements with capacitive sensors and integrators - coming soon at <http://www.highvoltageprobes.com/downloads.html>

Static or Capacitive Discharge “Sticks” are available from North Star High Voltage at www.highvoltageprobes.com. These sticks are rugged devices for discharging anything which can store a charge. Protect your ears if you expect any discharge to occur.



Our static discharge stick.