



North Star High Voltage  
12604 N New Reflection Dr,  
Marana, AZ 85653  
520 780 9030; (206)219-4205 FAX  
[www.highvoltageprobes.com](http://www.highvoltageprobes.com)

**DANGER - Voltages of up to 2.5 kV are generated by this unit Ignitron circuits to which this is connected may have even higher voltages. Disconnect from ignitron and external HV before servicing.**

## IG5F2- N Ignitron Driver Manual

(N = cable length in meters -example IG5F2-10 = unit with a 10 meter cable length)

Serial Number \_\_\_\_\_

Test V open \_\_\_\_\_

Test I short w/protection: \_\_\_\_\_

Test I Short w/o protection: \_\_\_\_\_

Life Test start \_\_\_\_\_

Life Test finish \_\_\_\_\_

Serial Number \_\_\_\_\_

Phone 520 615 4856  
FAX 206 219 4856  
e-mail: Radler2@Compuserve.com  
web www.highvoltageprobes.com

## 1. General

The IG5F2-10 Ignitron driver is designed to meet the specifications for triggering all ignitrons. It also provides a trigger isolation capability of 25 kV. It's specifications are:

Stored Energy:	3.6 Joule at 1.0 Hz.; 3 J at 2 Hz.
Open Circuit Voltage:	1.80 kV at 1.0 Hz.
Current:	370 A output into typical ignitron ignitor (1 Hz.) (Protection network not in use)
AC Input Voltage:	100 - 125 VAC input or 200 - 250 VAC input using internal slide switch. Failure to set the unit properly when using the higher voltage will destroy the unit.
Input Pulse:	5 V/20 mA if fiber optic transmitter accessory board is used Note that most 10 mA sources will drive a 3 m cable.
Input Pulse Duration:	3 - 100 usec (Triggers on rising edge)
Output Voltage Isolation:	25 kV to the input voltage
Fuse:	1/8 A internal - 220 VAC; 1/4A internal 110 VAC
Supplied Fiber:	10 m. standard      HP/Agilent Versatile Fiber Type
Trigger Delay:	1200 ns. Typical
Status Indicators:	TRIG TEST (See figures for TRIG TEST output characteristics) PS STATUS
Storage Temperature:	-20 C - 45 C
Operating Temperature	5C - 40 C

## 2.0 Installation

Connect a versatile fiber trigger signal to the input fiber optic. The BNC/fiber adapter may be used to supply the trigger to the unit by applying a 5 - 15 V pulse to the BNC. TTL signals which meet typical TTL requirements will trigger the unit (5 V, 5 mA).

Connect the output marked "Ignitor" to the Ignitor pin, and connect the output marked "Cathode" to the cathode. These connections should be secure and capable of conducting 400 A pulsed. The accessory board has components which help protect the unit against certain failures of the ignitron itself. The accessory board should be placed near the cathode, and it should not be grounded.

Open the unit and check the internal switch to assure that the power is set to the type of power line you plan to use. **If the internal power switch is not set correctly the unit may fail.** The factory setting is always for 220 VAC. Connect the input power (220 VAC nominal or 110 VAC nominal) to the AC receptacle once the settings of both switches are assured. If a powered trigger module has been supplied, check the settings of that unit before use.

Pulse the unit. Check the connections without HV applied to the ignitron to make sure that the contacts are not arcing. The unit will make an audible "ticking" noise when triggered.

### 2.1 Fiber optic cable

Do not kink the fiber optic cable - try to keep the fiber optic cable radius of curvature >7 cm if possible. 1 mm plastic fiber is used so there is attenuation.

## 3.0 Mounting

A diagram for mounting the unit is appended. Studs used are Metric system M8. The unit may be mounted in any orientation, and the unit itself should be grounded. The accessory board on the fly leads should not be grounded.

## 4.0 Applications

The IG5-F is an ignitron driver supplied with the capability for isolation of the output. For circuits where the cathode is floating, such as series ignitron applications, the circuit can derive power from the external circuit:

Circuit A      Recommended Wherever Possible

In circuit A, the cathode of the ignitron is grounded. If this circuit can be used, cooling of the ignitron jacket is simplified, along with triggering and monitoring. The unit power

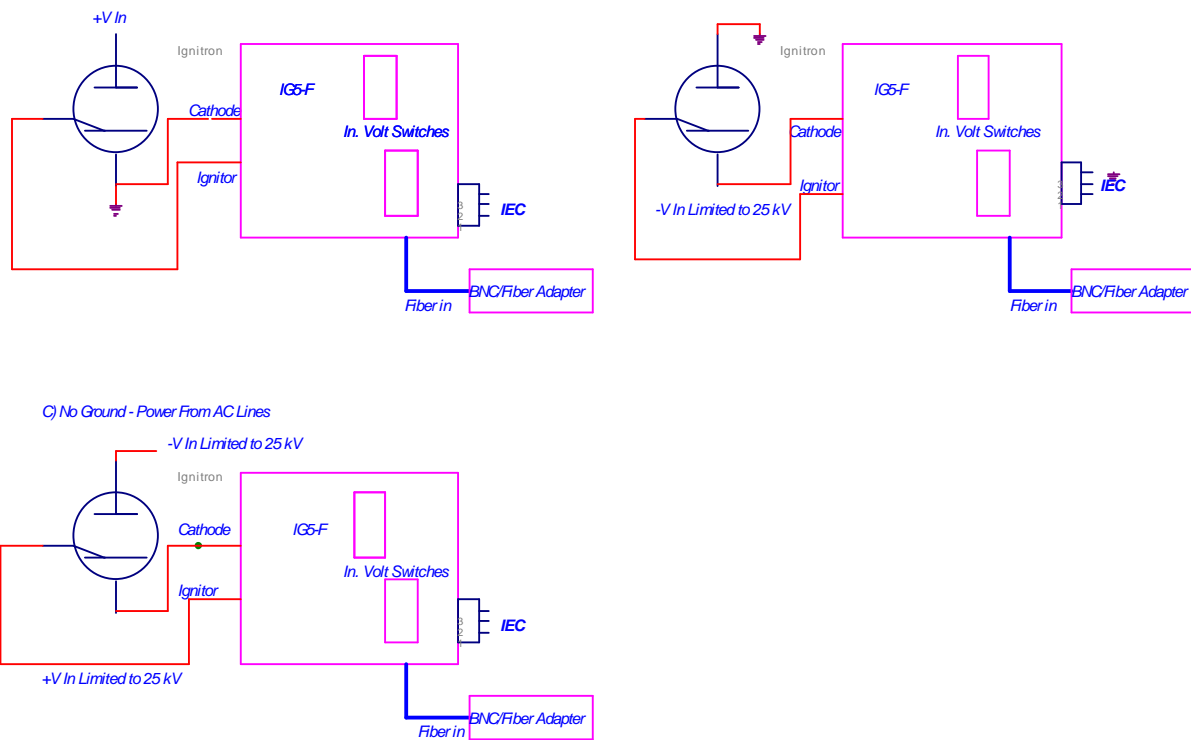

Figure 1 Application scenarios. The metal box should always be grounded.

is connected to line voltage, the fiber is inserted into the driver, and the unit triggers with each light pulse. The input power ground should be grounded (IEC plug and chassis ground).

#### Circuit B Lower Value Biases

In circuit B, the cathode of the ignitron is at some potential up to 25 kV from ground. If this circuit can be used, heating of the anode insulator is simplified, along with triggering and monitoring. The unit power is connected to line voltage, the fiber is inserted into the driver, and the unit triggers with each light pulse. An MOV of appropriate voltage connected from either of the line voltages (preferably neutral if such exists) to the preferred earth ground may be desirable. No voltage can exceed 25 kV relative to ground. The input power ground should be grounded (IEC plug and chassis ground).

#### Circuit C Floating Ignitron Powered by AC

In circuit C the circuit derives its power from AC voltage, but neither the cathode or anode is grounded. The voltage difference between the cathode/ignitor and anode must not exceed the 25 kV including during transients. No voltage can exceed 25 kV relative to ground.

## **5.0 Grounding**

The box is designed for grounded operation. If floating operation is necessary, the signal source and power source must be floated to the same potential. The difference between the power voltage and the box voltage should not exceed 700 V peak.

## **6.0 Power Supply Voltage Monitor**

The monitor labeled PS Status has an output when the power supply driving the SCR is "ready". This will fail to light if the 600 V internal power supply or SCR fails.

## **7.0 Output Protection Board**

An accessory consisting of an 8 kV diode, and 3 kV spark gap is provided on all boards. This accessory prevents positive voltages of greater than 3 kV from being applied to the trigger unit. Negative voltages are protected by diodes in the unit itself. Such voltages are sometimes applied to the ignitor during a ringing discharge.

The current output is reduced by about 50 A when this board is in use. If this is undesirable for a given application, then the board need not be used. The fly leads can be cut and stripped for use without this board. Use of this board is optional, but removing this board will make the unit more sensitive to certain failures of the ignitron itself. Removal of the board may void the warranty if certain types of failures occur.

The board should either be floating or at the same potential as the Ignitron Cathode. The board only protects against fault modes associated with positive anode/negative cathode (standard) operation of the ignitron. In the non-standard oscillatory mode which is sometimes used, the driver can be subjected to the full power of the capacitor bank. The driver is not protected against an arc between anode and the ignitor.

## **8.0 Warranty**

The unit is warrantied for 1 year against defects in manufacturing and most failures. If warranty service is requested the type of ignitron, ignitron/capacitor bank circuit schematic, and any other relevant information must be supplied. The unit is not warrantied for oscillatory current applications where the current through the ignitron reverses.

## Figure of TRIG TEST output characteristic

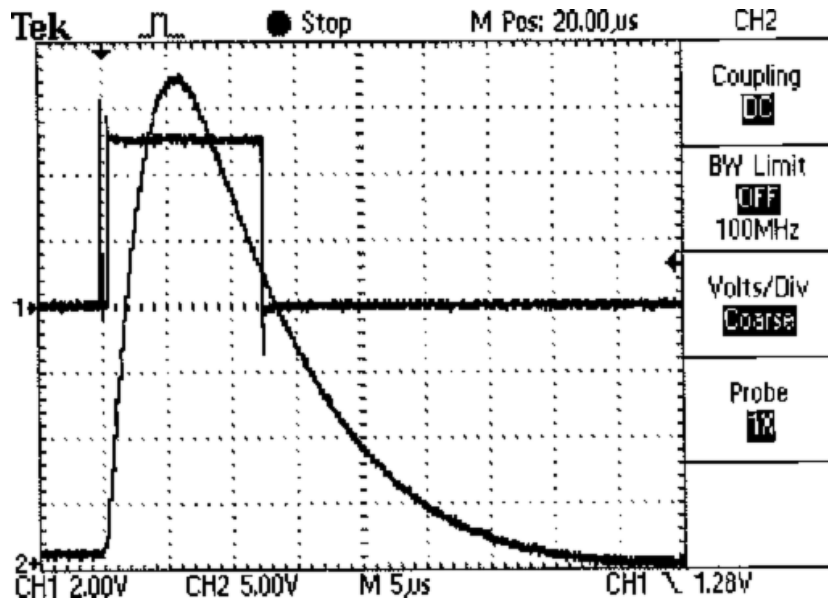

Fig. 2 Short Circuit Monitor and Current.

Figure 2 shows the current in the output along with the monitor output for the case where the ignitron ignitor fires immediately. The monitor is on for 10 - 15 microseconds and it's main pulse starts within 2 microseconds of trigger initiation. This corresponds to nominally good performance.

Figure 3 shows the open circuit/open ignitor case. A pulse after saturation of the transformer, delayed by approximately 5 microseconds. In most situations, the pulse should appear in 4 microseconds or less time after initiation of the pulse from the fiber.

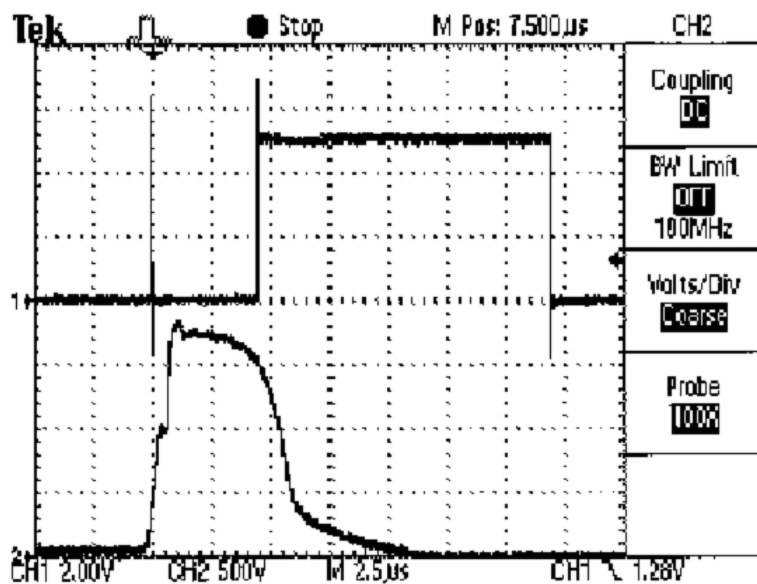
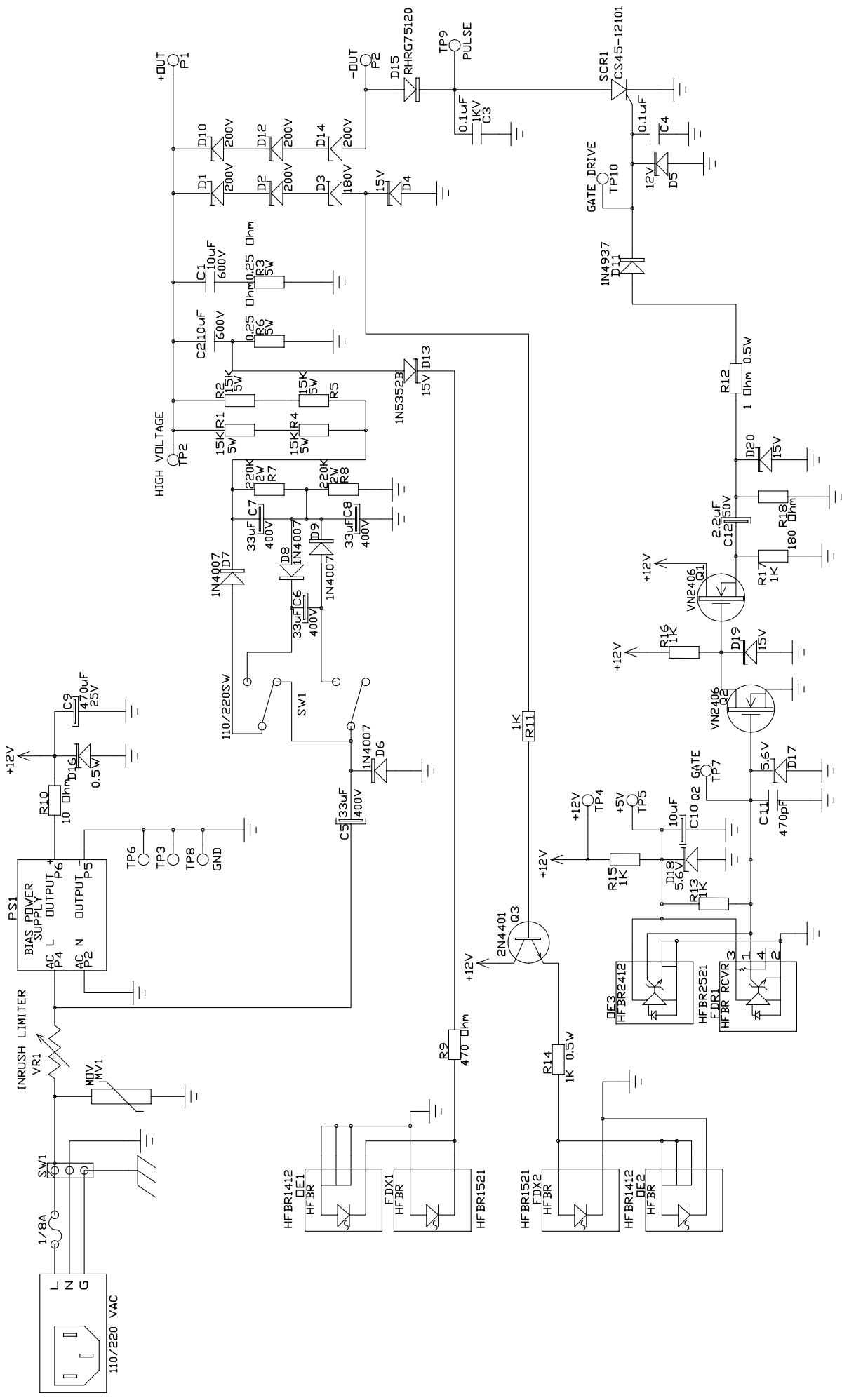

Fig. 3 monitor and open circuit voltage

## SPECIFICATIONS IG5F2-10

The IG5F2-10 Ignitron driver is designed to meet the specifications for triggering all ignitrons. It also provides a trigger isolation capability of 25 kV. It's specifications are:

Stored Energy:	3.6 Joule at 1.0 Hz.; 3 J at 2 Hz.
Open Circuit Voltage:	1.80 kV at 1.0 Hz.
Current:	370 A output into typical ignitron ignitor (1 Hz.) (Protection network not in use)
AC Input Voltage:	100 - 125 VAC input or 200 - 250 VAC input using internal slide switch. Failure to set the unit properly when using the higher voltage will destroy the unit.
Input Pulse:	5 V/20 mA if fiber optic transmitter accessory board is used Note that most 10 mA sources will drive a 3 m cable.
Input Pulse Duration:	3 - 100 usec (Triggers on rising edge)
Output Voltage Isolation:	25 kV to the input voltage
Fuse:	1/8 A internal - 220 VAC; 1/4A internal 110 VAC
Supplied Fiber:	10 m. standard      HP/Agilent Versatile Fiber Type
Trigger Delay:	1200 ns. Typical
Status Indicators:	TRIG TEST (See figures for TRIG TEST output characteristics) PS STATUS
Storage Temperature:	-20 C - 45 C
Operating Temperature	5C - 40 C



NORTH STAR RESEARCH	
6/30/03	RLD
8/23/03	TITLE
9/24/03	IGS SCHEMATIC DIAGRAM
DRAWING NO. IGS_062503 REV 3	

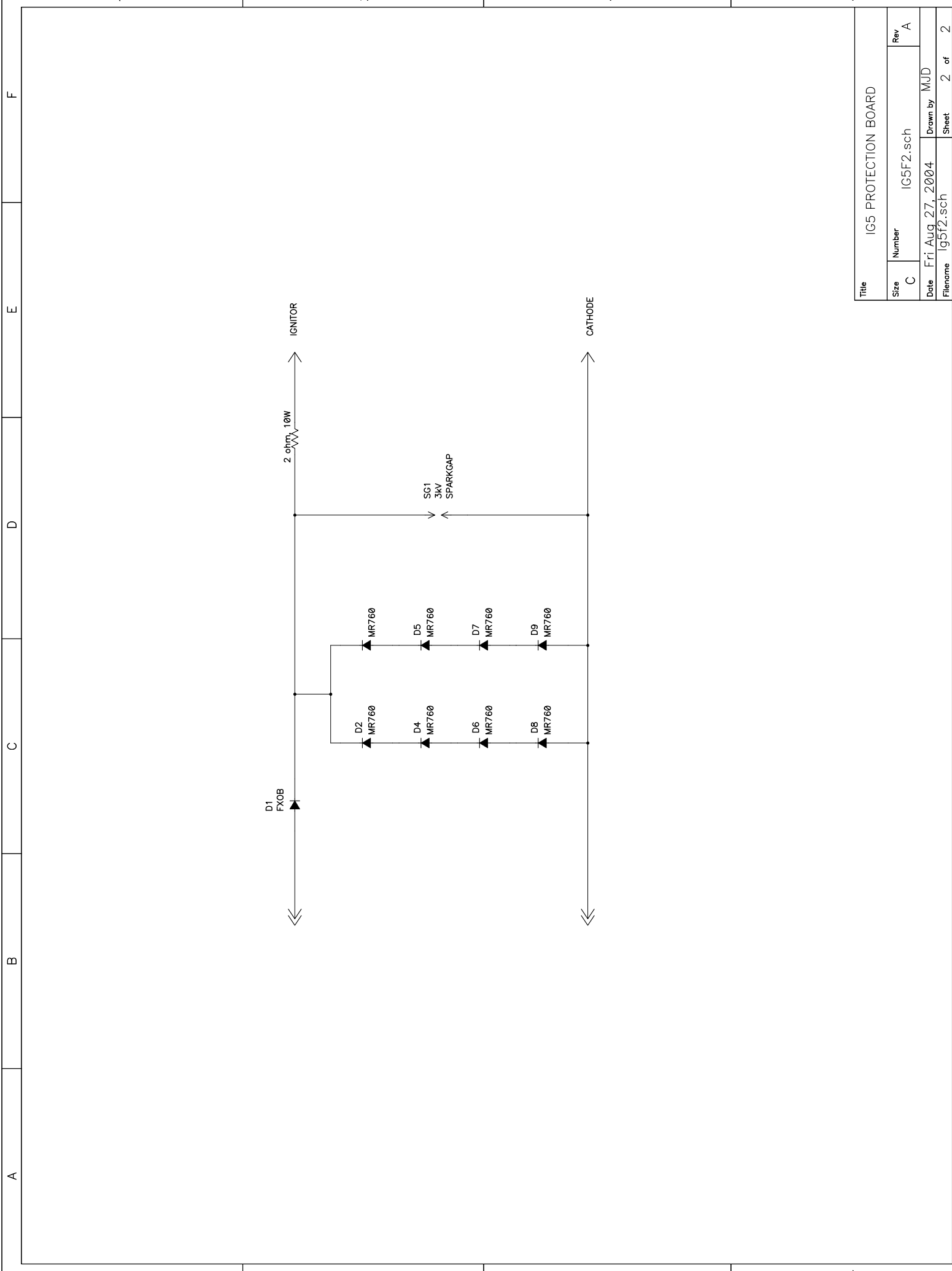

Title				IG5 PROTECTION BOARD			
Size	C	Number	IG5F2.sch	Rev	A		
Date	Fri Aug 27, 2004			Drawn by	MJD		
Filename	I95f2.sch			Sheet	2	of	2

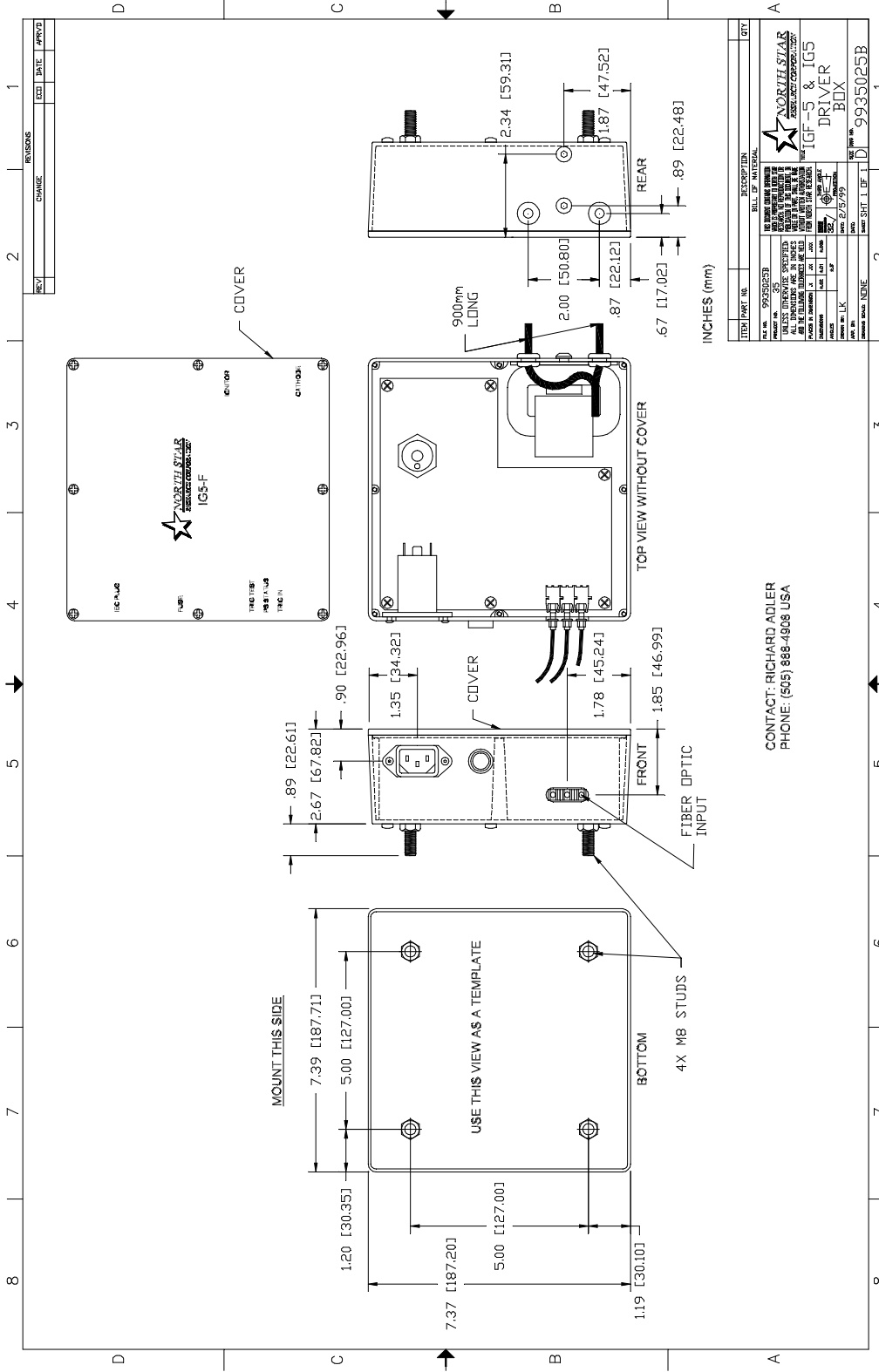

ITEM	QTY	DESCRIPTION
9935025B	1	DRIVER BOX
9935025B	1	COVER

ITEM	QTY	DESCRIPTION
9935025B	1	DRIVER BOX
9935025B	1	COVER

CONTACT: RICHARD ADLER  
PHONE: (505) 888-4908 USA

ITEM	QTY	DESCRIPTION
9935025B	1	DRIVER BOX
9935025B	1	COVER